

: visi electrode

dedicated electrode design

VISI Electrode is an automated module for the creation and management of electrodes and their holders for the manufacture of detailed and hard to machine features on mold and press tools. Comprehensive holder design, simulation and collision checking ensures that the electrode will operate right first time.

EDM electrode creation can be one of the most complex and time consuming projects for any mold or die maker. The VISI suite of products offer a solution at every point of the manufacturing process from design to manufacture. Even the most experienced electrode designer will benefit from the knowledge based automation provided by VISI Electrode.

Burning area extraction.

After identifying the areas which need automation provided by VISI Electrode to be manufactured with an electrode, enclosing the area with a 2D or 3D boundary provides a quick and simple way to arrive at the required electrode geometry. Graphical face selection is also available to permit easy extraction of the more complex areas. Understanding that VISI Electrode is a tool to compliment the experience of electrode designers, VISI combines automation with the ability to manually construct geometry and apply it to the electrode. This technology combination provides the user with the freedom to edit the design and ensures that it will always be possible to complete the electrode design.

Electrode creation.

An intuitive interface guides the user through the creation of the electrode nose. Options are available for adding extension height with either vertical or tangential extension. For open-sided electrodes, multiple extrusion directions are available for side extension. At any point within the electrode creation process, dynamic animation and collision checking is available.

dynamic surface
extraction

linear and tangential
surface extension

electrode collision
checking

electrode holder
libraries

vertical / side / inclined
electrode animation

neutral data
file export

HTML and EPX
export

template tool paths
using VISI Machining

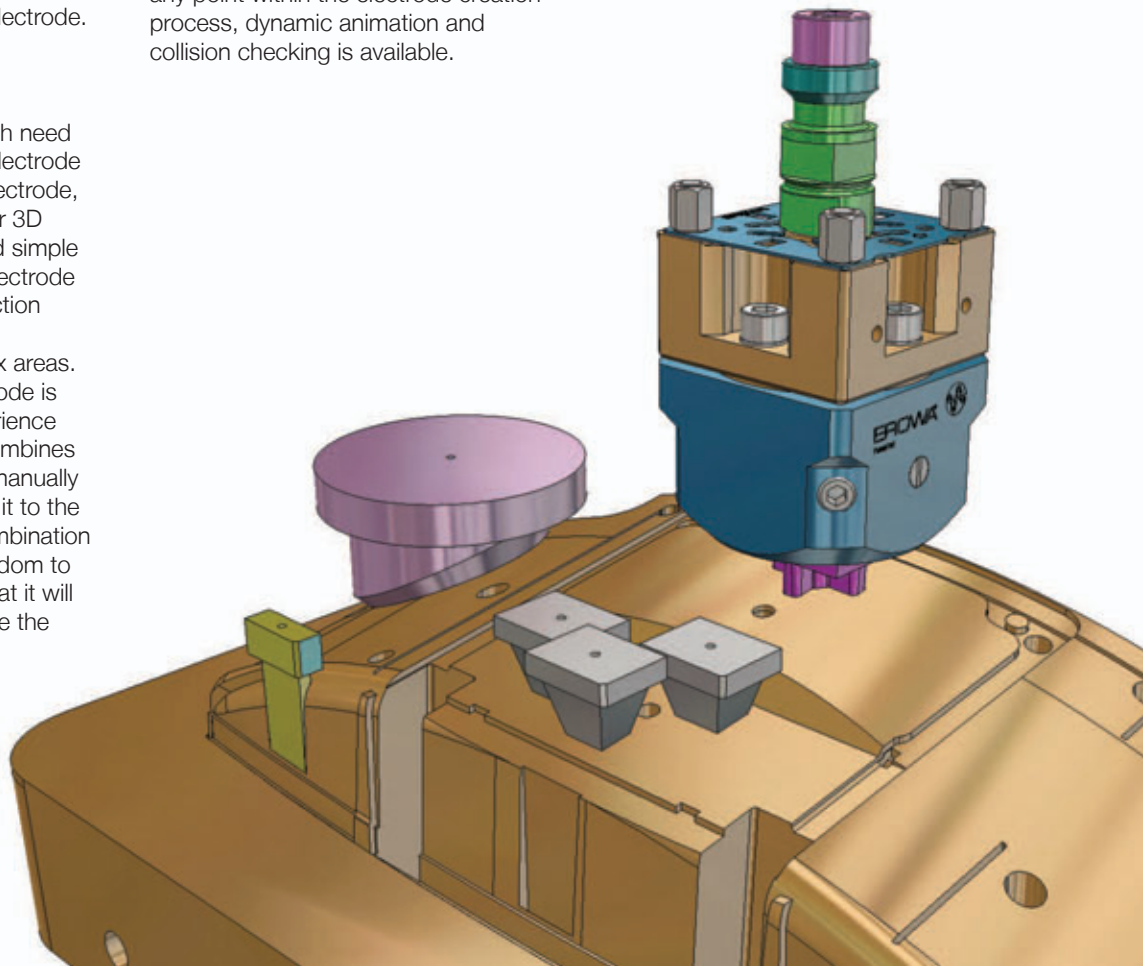

Even the most experienced electrode designer will benefit from the combination of knowledge based automation and user interaction provided by VISI Electrode. The combination of solid and surface technology will provide a step change in productivity.

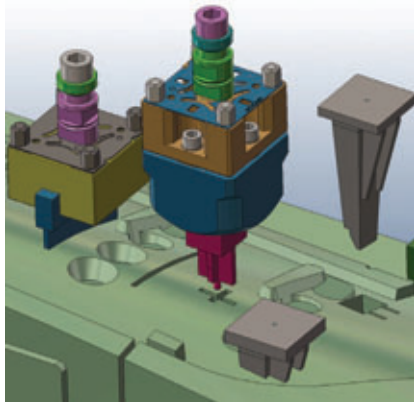

Blank, base and stock creation.

The electrode base and stock are interactively added to the electrode. Electrode name, material, burning operation type, identification marks, edge chamfers, position and rotation can all be applied. Any information added is automatically carried through the electrode project to the final HTML report.

Holder creation.

Holders can be constructed manually by applying width, depth or height, or simply selected from an extensive library. Where access for the electrode is limited by neighboring surfaces, the holder can be offset from the center of the electrode to provide enough clearance for the EDM machine to operate. Dynamic animation and collision checking ensure that the complete electrode does not violate the part geometry.

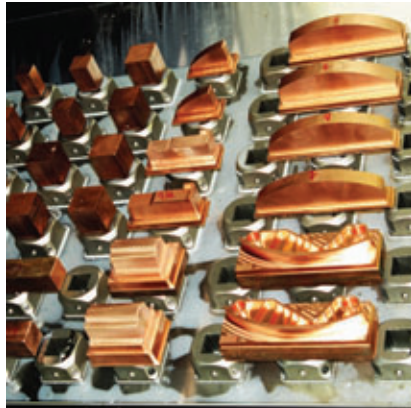

Electrode management.

The EDM manager provides the operator with a tool to manage the work piece, electrode, multiple electrode positions, vertical, horizontal and angled simulation, collision checking, HTML report and EPX output. To ensure compatibility with other CAD/CAM systems, each electrode can be automatically exported relative to the correct workplane using a neutral data format such as IGES, STEP or STL.

Animation and collision checking.

To ensure that the electrode and holder are correct, the electrode can be graphically animated along its axis of operation. Automatic checking will test for interference between the electrode and neighboring surfaces. Any collision will be graphically highlighted and the electrode will be moved to the point of contact.

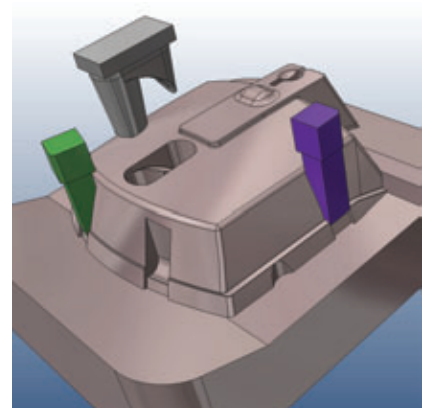

Datum creation and manufacture.

Once the electrode has been designed it can be machined directly (without any unnecessary data transfer) using VISI Machining. A datum for machining and positioning the electrode in the EDM machine is automatically created to ensure continuity throughout the entire manufacturing process. Machining templates containing tooling, tool path operations, feeds, speeds, depth of cut, etc. can all be stored for re-use on similar electrode families. Applying them to a new electrode will automatically create a new set of toolpaths using the same settings, greatly reducing programming time and using company standards which have already been proven on a previous job.

Original Concepts Design, Inc.

1200 S. Church St.
Suite 9
Mount Laurel, NJ 08054
USA

Authorized Distributor of Vero software

tel. 856 787.1911
fax. 856 380.0888
email. info@vero-var.com
web. www.vero-var.com

